

# Actuator 2 – Hydraulic and Pneumatic Actuation

ME490A/B

Dr. C. Alex Simpkins

SDSU

Dept. of Mechanical Engineering

Adapted from a presentation by Dr. Kee  
Moon

# Excavators

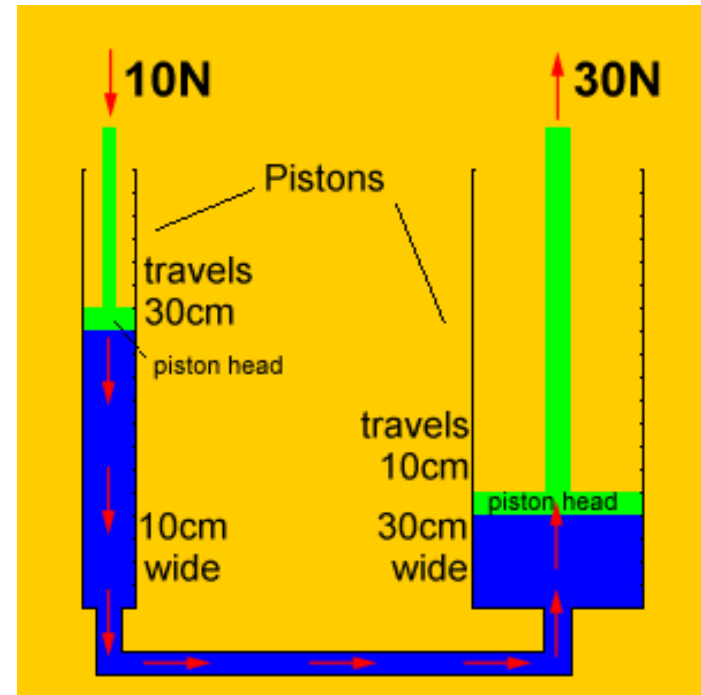

# Excavator hydraulics

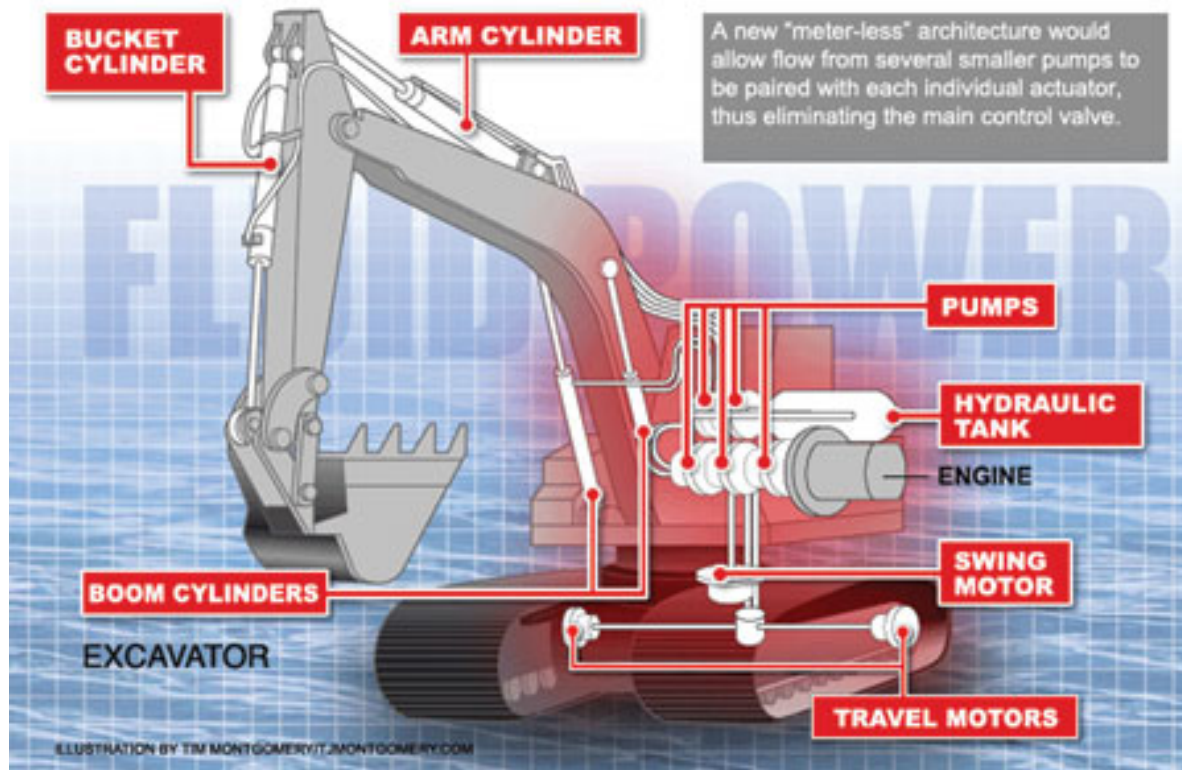

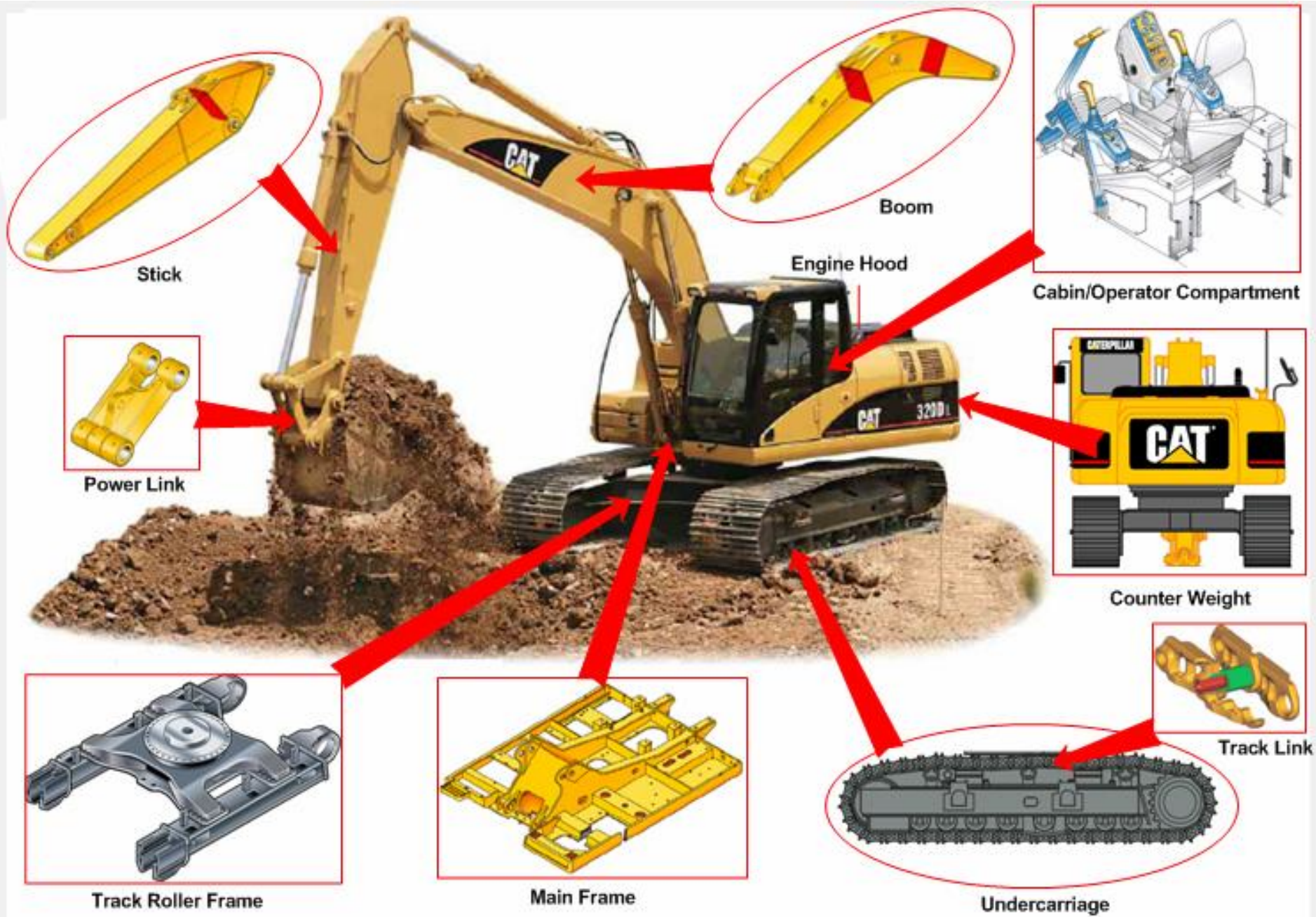

# A typical hydraulic system

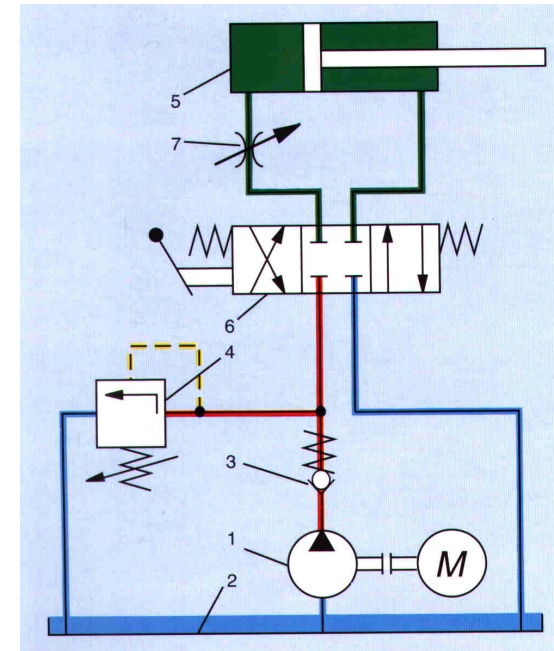
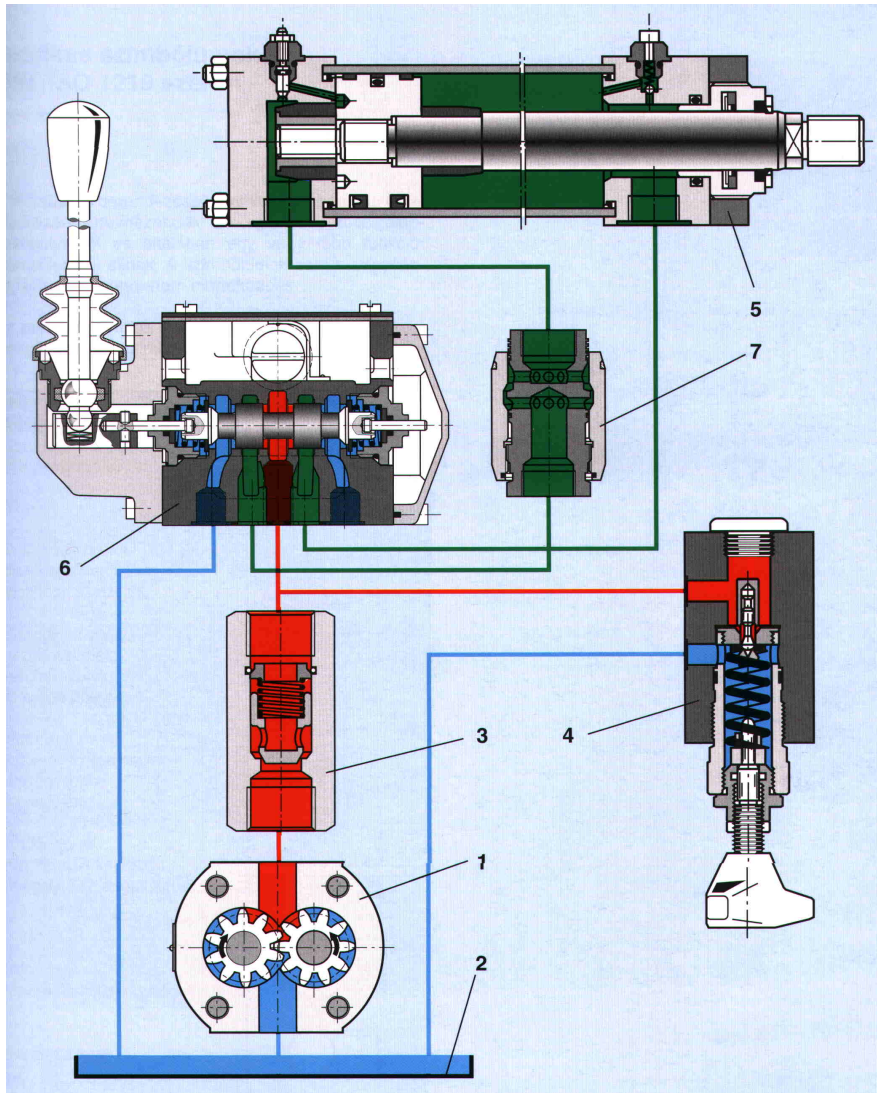

- 1 – pump
- 2 – oil tank
- 3 – flow control valve
- 4 – pressure relief valve
- 5 – hydraulic cylinder
- 6 – directional control valve
- 7 – throttle valve

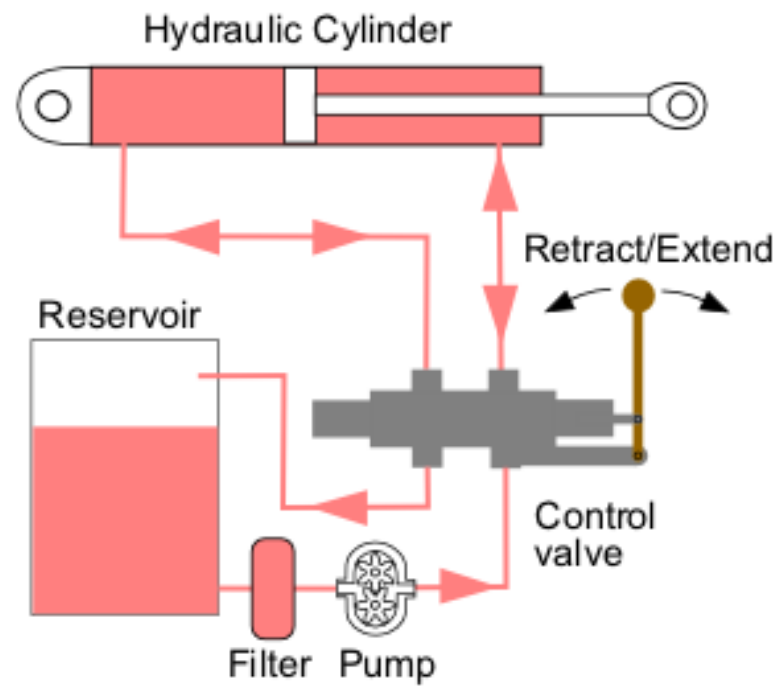

[http://www.youtube.com/watch?v=wm-E\\_YNv0ek](http://www.youtube.com/watch?v=wm-E_YNv0ek)

## *Advantages of hydrostatic drives*

- 👍 Simple method to create linear movements
- 👍 Creation of large forces and torques, high energy density
- 👍 Continuously variable movement of the actuator
- 👍 Simple turnaround of the direction of the movement, starting possible under full load from rest
- 👍 Low delay, small time constant because of low inertia
- 👍 Simple overload protection (no damage in case of overload)
- 👍 Simple monitoring of load by measuring pressure
- 👍 Arbitrary positioning of prime mover and actuator
- 👍 Large power density (relatively small mass for a given power compared to electrical and mechanical drives)
- 👍 Robust (insensitive against environmental influences)

## *Disadvantages of hydrostatic drives*

- 👎 Working fluid is necessary (leakage problems, filtering, etc.)
- 👎 It is not economic for large distances

# A New Excavator without vibration problem?

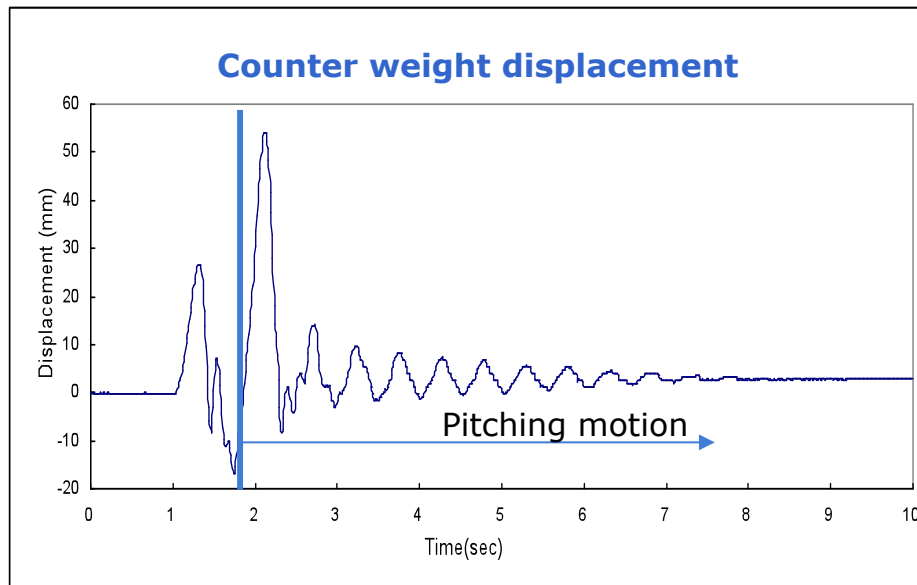
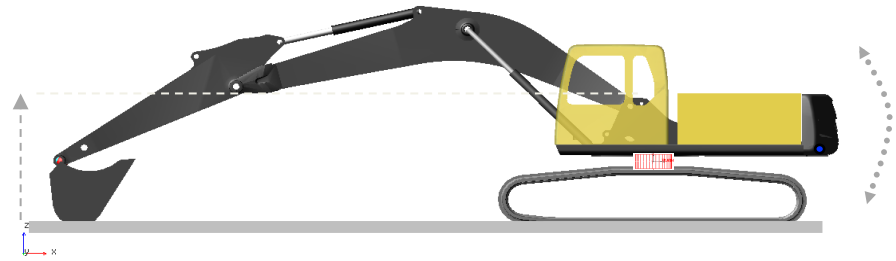

Conventional pitching test:  
experimental result (ec290)

Max. CWT displacement:  
55mm,  $\sim 1.5$  Hz.

► Sensor distribution map for the pitching data acquisition

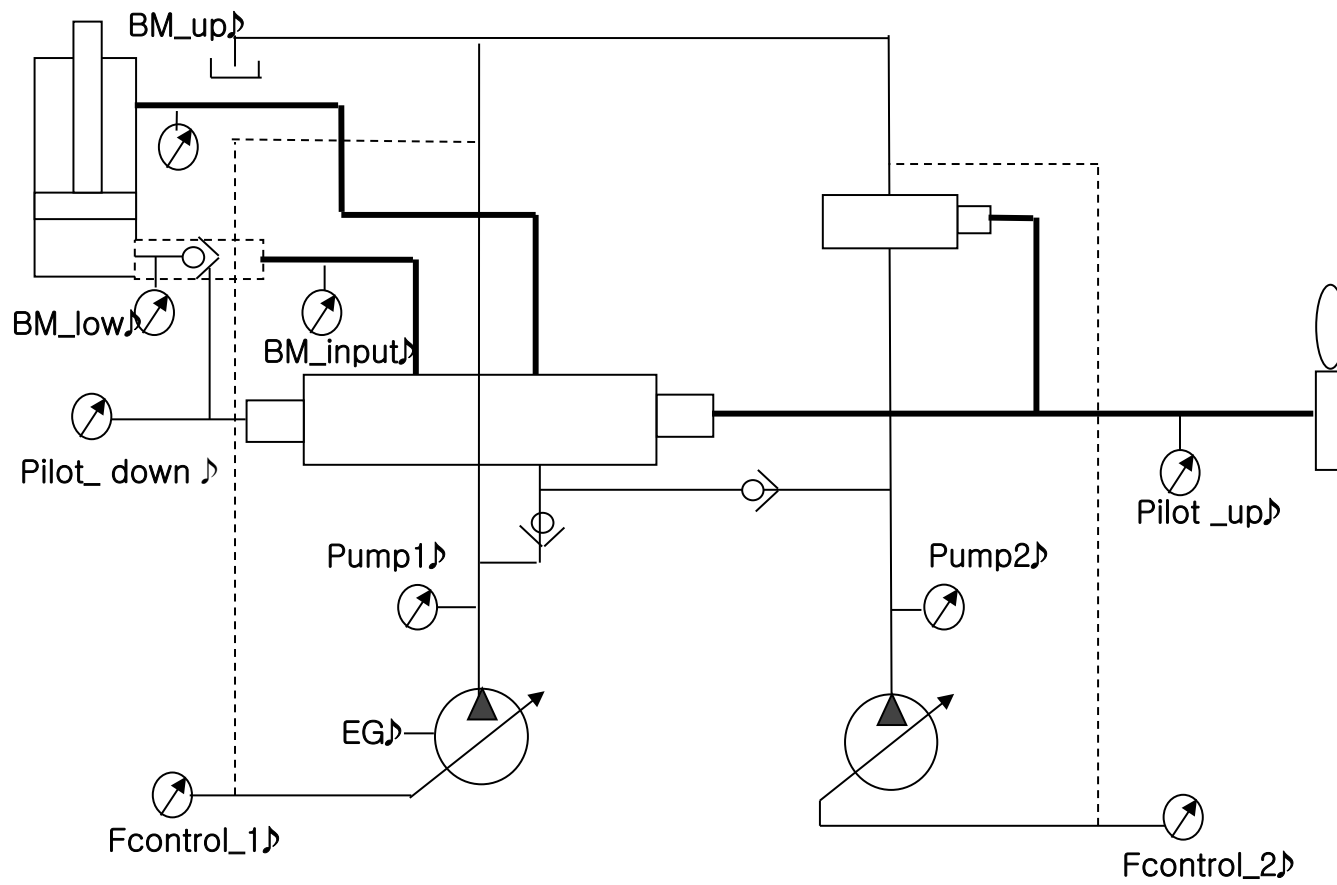

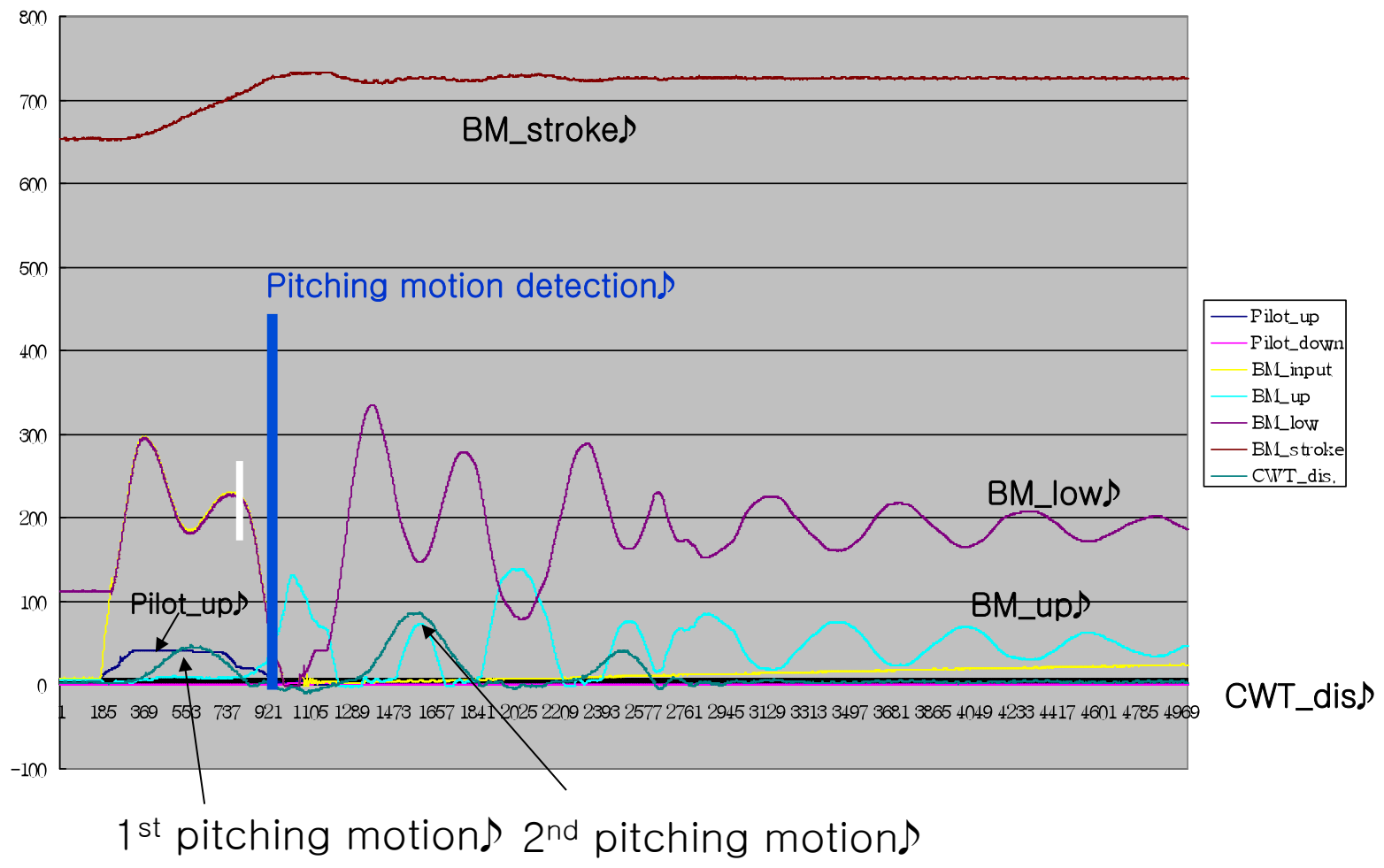

- Pilot\_up
- Pilot\_down
- BM\_input
- BM\_up
- BM\_low
- BM\_stroke
- CWT\_dis.

- ▶ Pitching motion mechanism – boom lifting mechanism
- ▶ Frequency response of the system
- ▶ Time delay analysis
- ▶ Optimum sensor locations to detect pitching motion :  
Boom\_upper and Boom\_lower chamber pressures

- ▶ Pitching motion mechanism

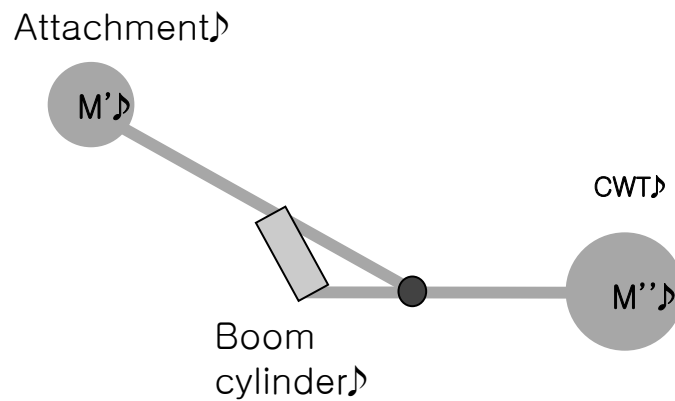

### Energy flow ↴

Kinetic energy of the attachment ↴



Potential energy of the boom cylinder ↴



Kinetic energy of the CWT ↴

- ▶ Prototype schematic diagram to represent the pitching motion

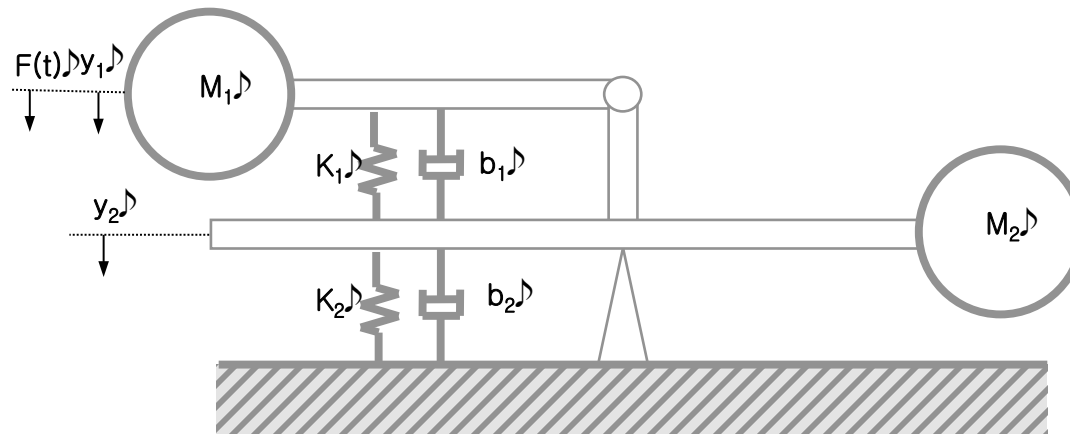
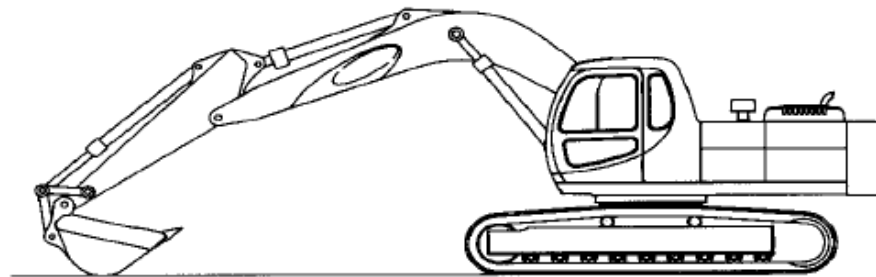



- ▶ Simulated sensor signals to the DSP
  - Voltage signal from D/A converter to the DSP
- ▶ To test the control program of the DSP
  - Voltage signal from DSP to A/D converter
  - Various control environments

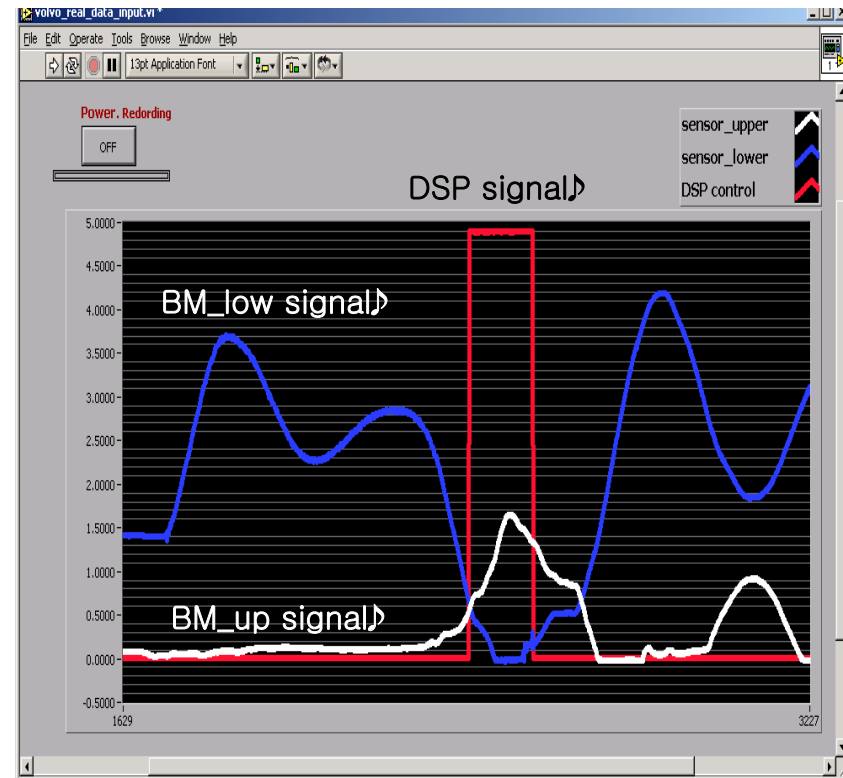
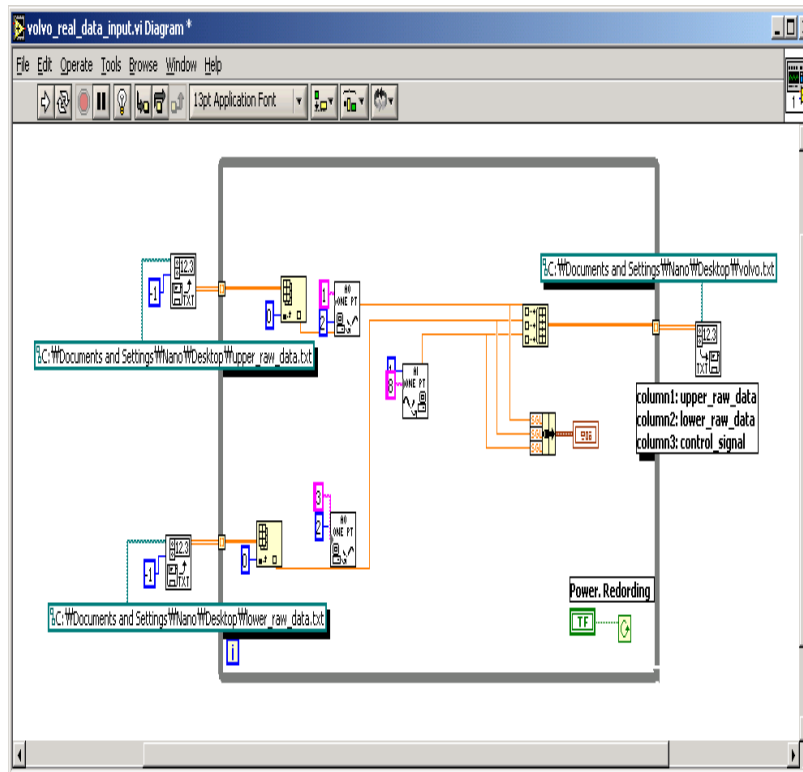

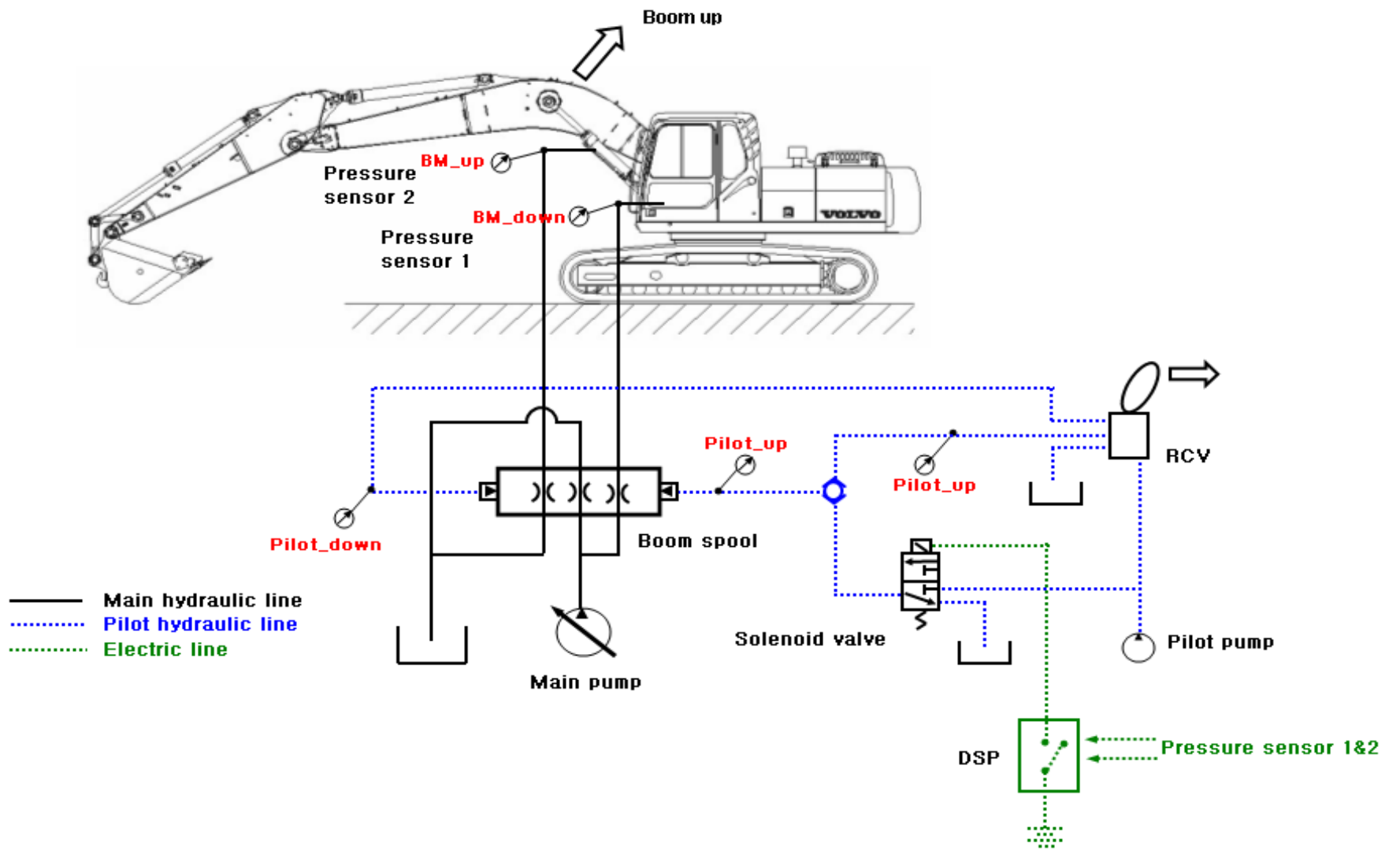



- ▶ Pressure sensors
  - Boom-up chamber
  - Boom-low chamber
- ▶ Boom stroke sensor



- ▶ DSP controller

- ▶ Solenoid actuation controlled by DSP

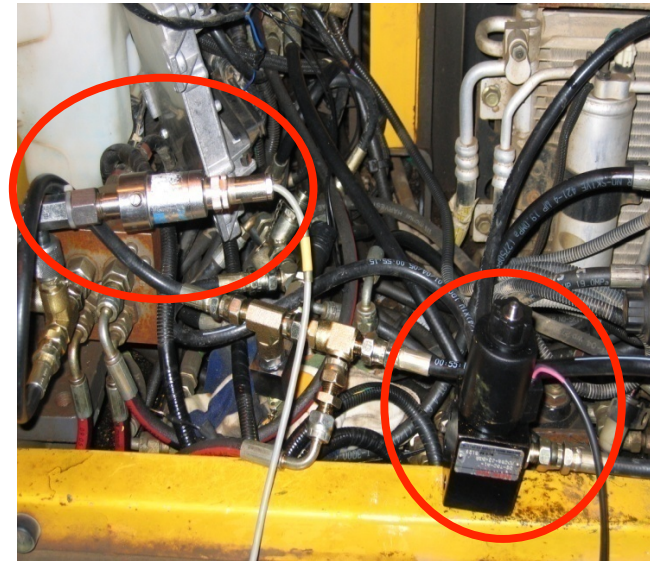

Non-controlled pilot pressure and CWT displacement

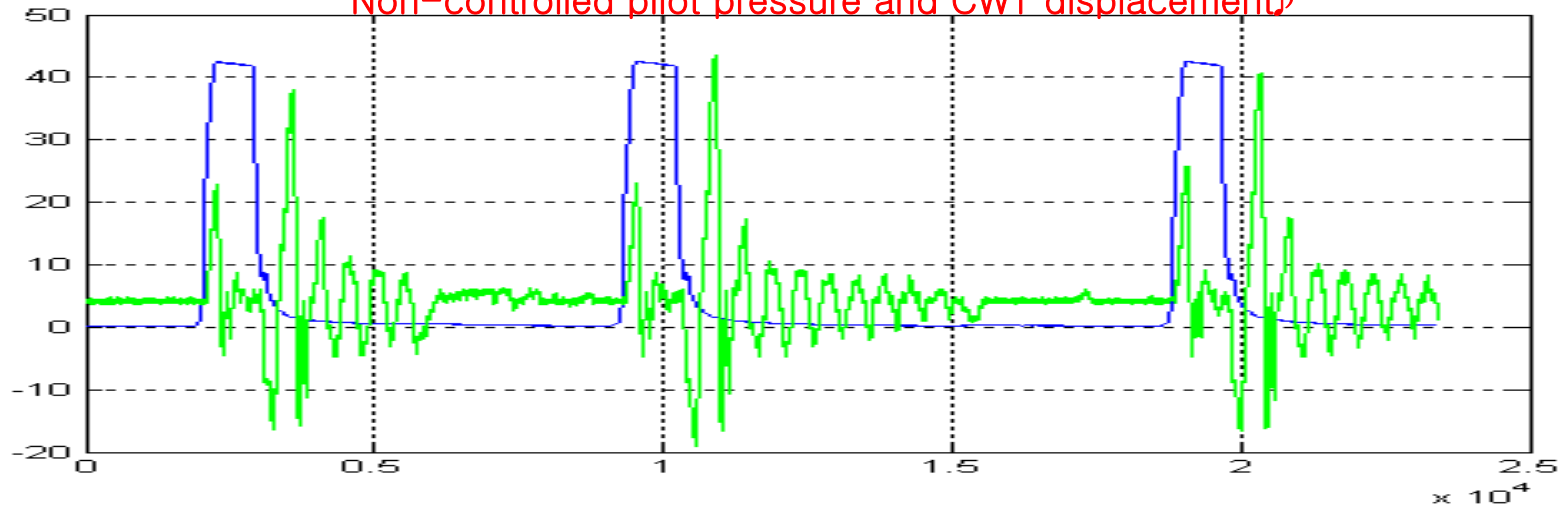

Controlled pilot pressure and CWT displacement

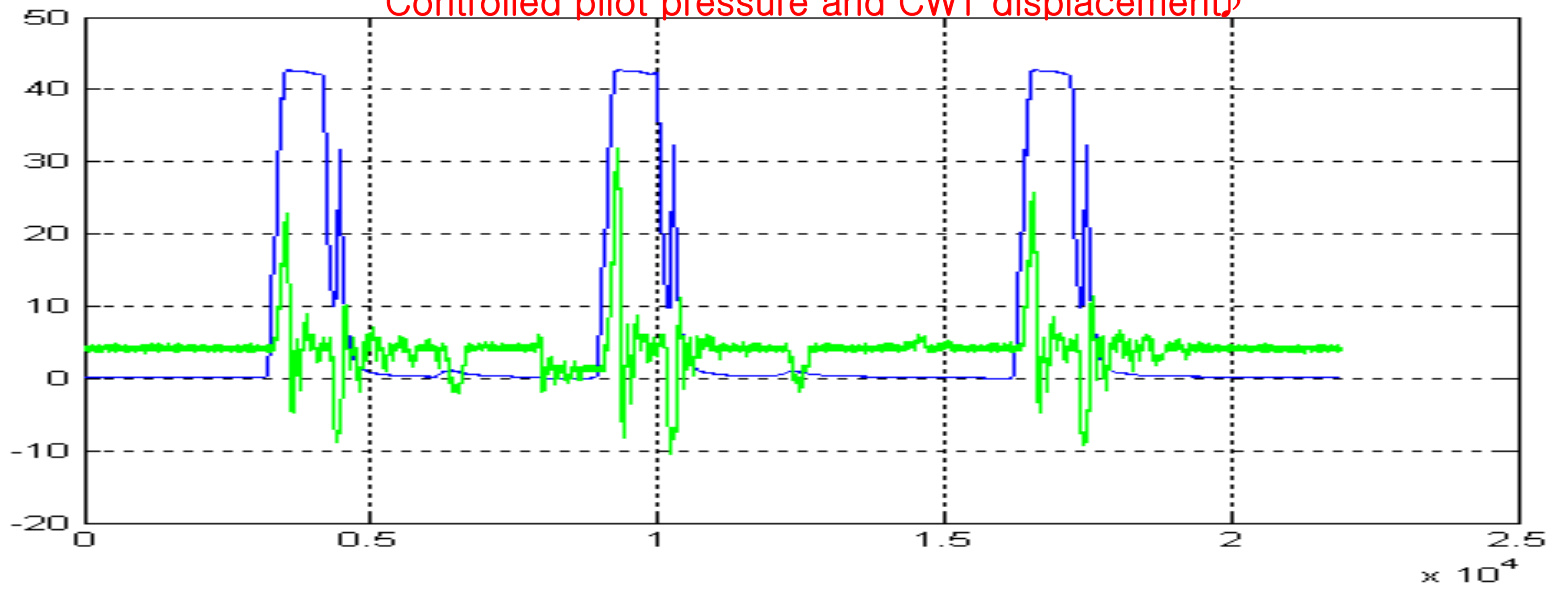

# What are pneumatics

- Mechanisms which use air pressure to apply mechanical force and displacement (work)
- The pneumatic devices we use are basically binary actuators – either retracted or extended

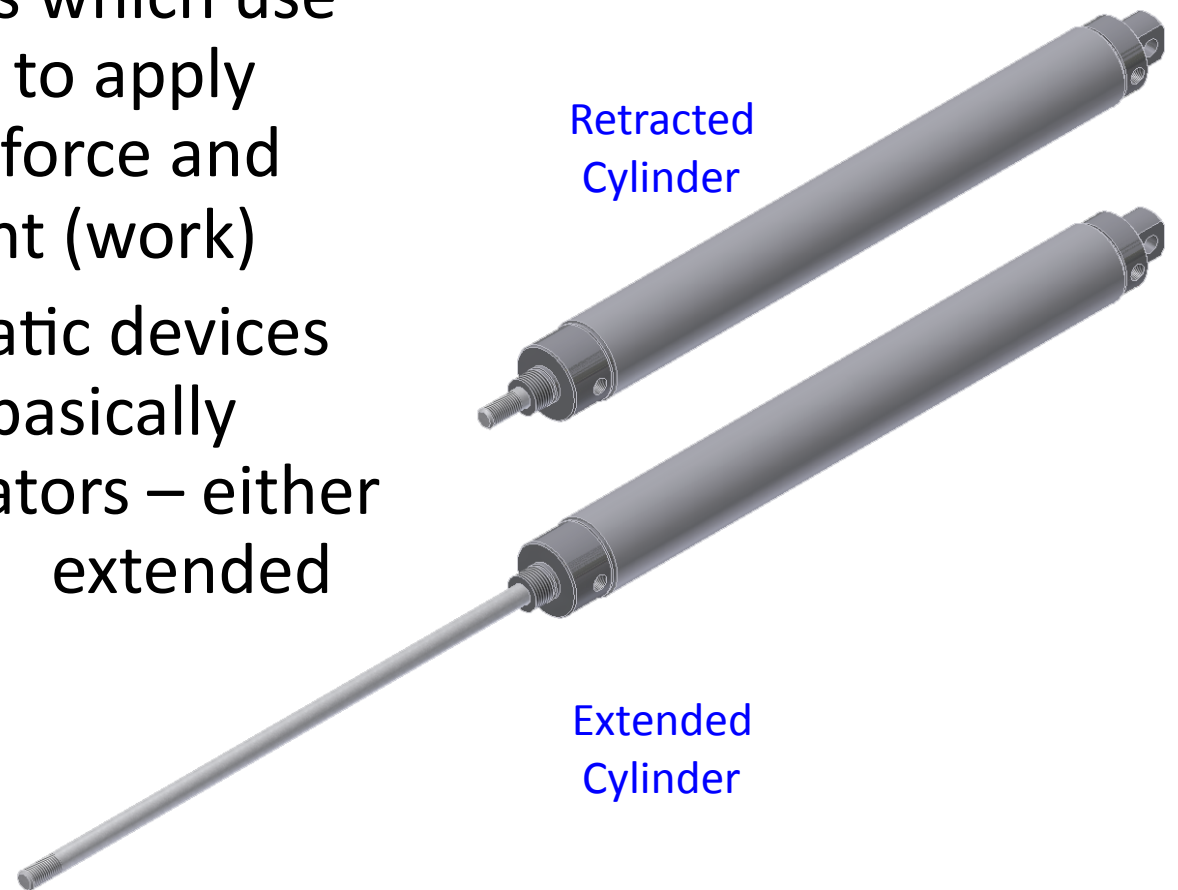

# Pneumatic Actuation

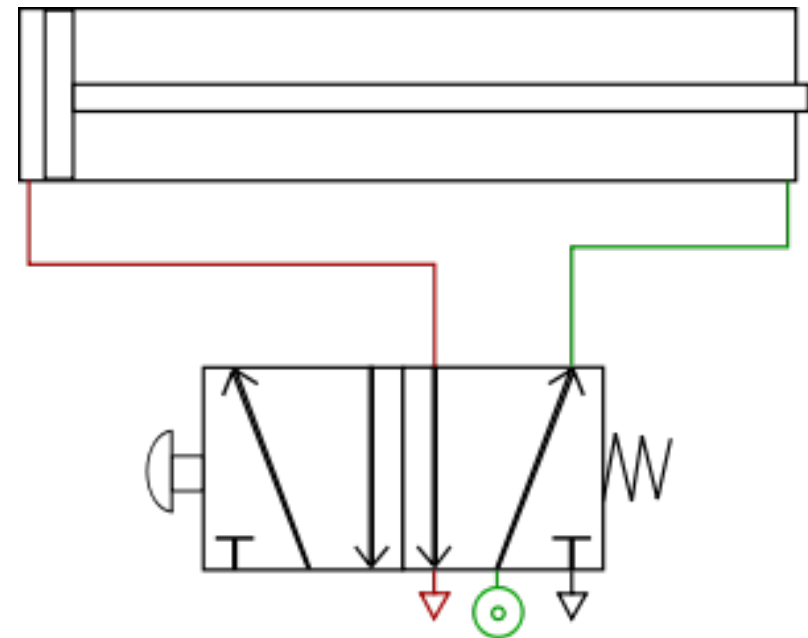
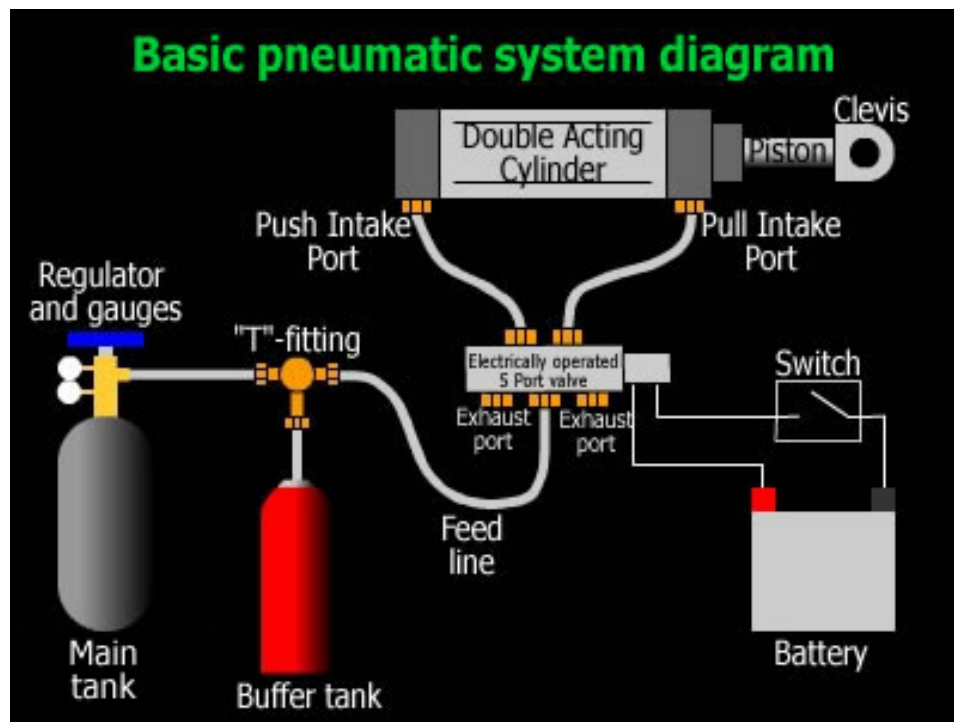

# Pneumatic Control Valve

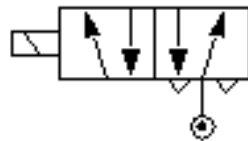

The solenoid has two positions and when actuated will change the direction that fluid flows to the device. The symbols shown here are commonly used to represent this type of valve.

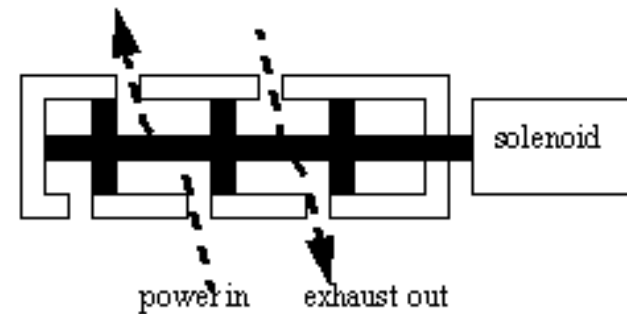
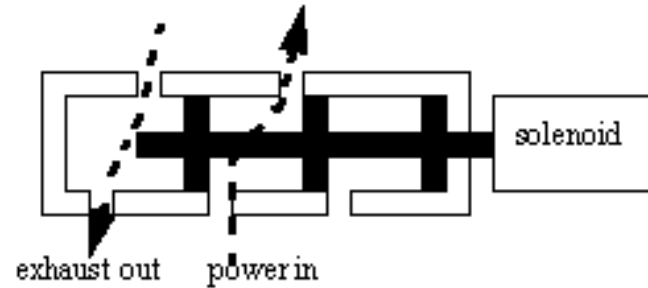
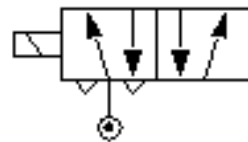

# Reading Pneumatic Schematic Symbols

## The Block

The block symbolizes the possible valve functions or positions. Example: A 5/2 valve schematic will be illustrated with 2 blocks describing two valve functions or positions. A 5/3 valve schematic will show three blocks describing 3 possible valve functions or positions.

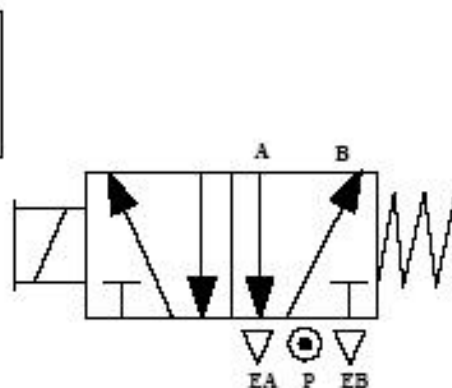

## The Arrows

The Arrow symbols illustrate the direction of gasses flowing into and out of the valve ports. Gas or pressure is supplied from port P. Depending on which of the valve blocks it is in function, the gas is directed to port A or B as shown by the arrows.



## The Actuator (Solenoid) Symbol



Pneumatic valves can be operated in several ways. Hand operated (including levers and push and or push pull buttons); Air piloted (Operated remotely by pneumatic signals); Solenoid (directly actuated with electronic signals)

5/2 Valve has 5 ports and 2 possible conditions

- 1.) B is pressurized and A is exhausted.
- 2.) A is pressurized and B is exhausted.

When the solenoid is NOT energized the B port is pressurized. The spring symbol defines the valve position at rest.



## The Return Spring

The spring symbol defines the "at rest" position of the solenoid valve. The spring "Pushes" from the side it is drawn on and places the right side block diagram of the valve in function.



## The T Symbol

This symbol indicates that a port is closed and is neither passing or exhausting gas.



## Exhaust Port Symbol

The inverted triangle symbol denotes an exhaust port. The letters EA indicate this is the exhaust port for the A circuit. Ebin turn indicates the exhaust port for the B circuit.



## Pressure or Air Supply Symbol

This symbol indicates the air supply port. In addition to this symbol the letter P or the number 1 also indicates the air supply port.

# Strengths

- Simple
- Easy to control
- Can apply a lot of force from a small, light package
- Force is limited by air pressure and cylinder diameter
- No adverse consequence if cylinder is stopped (no stalled motors) or reversed – compressed air is a spring

# Drawbacks

- Cylinders can be subject to damage
- Repair impossible

# The pneumatic system *(the solenoid valve)*

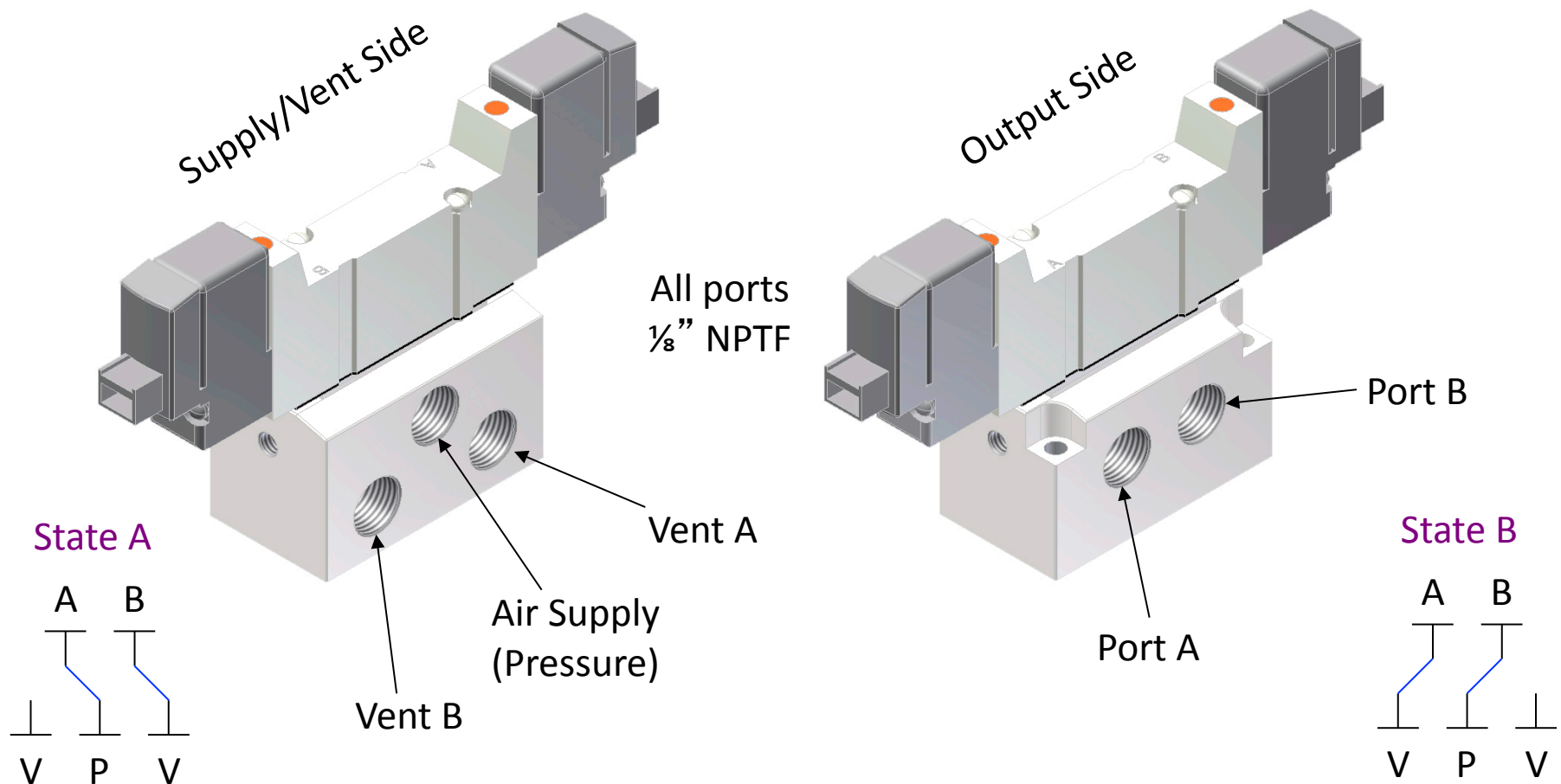

# The pneumatic system *(device control)*

